

GENERAL INFORMATION

1.0 SCOPE OF MANUAL

This manual contains operating and maintenance information for the Linear Integrating Totalizer (LIT) manufactured by MOORE INDUSTRIES INCORPORATED, Sepulveda, California. The manual consists of the following six sections:

Section 1. General Information, provides the physical and functional configuration of the unit. A model number explanation is also included.

Section 2. Calibration Procedures, provides information necessary for adjustment and calibration of the unit. This section contains a list of the tools necessary for adjusting the equipment. A test connection diagram is included.

Section 3. Installation and Operation, this section contains mechanical and electrical installation, which includes recommended wiring practices and electrical connections for the unit.

Section 4. Theory of Operation describes the circuit operating principles based on a simplified schematic diagram.

Section 5. Maintenance and Troubleshooting, gives step-by-step procedures for maintaining and troubleshooting equipment.

Section 6. Unit Documentation, contains schematic diagrams, assembly drawings, and installation and outline drawings.

The terms **NOTE**, **CAUTION** and **WARNING** have specific meanings.

A **NOTE** provides additional information that makes it easier to perform a particular task. Failure to follow a note may result in some inconvenience or needless expense, but the unit will not be damaged, nor is the Instrument Technician likely to be injured.

A **CAUTION** stresses important details to follow when making electrical connections or cleaning PC board contacts. Failure to heed a caution may damage the unit, void the Moore Industries warranty or cause minor physical injury to the Instrument Technician.

A **WARNING** provides vital safety information that must not be ignored. Warnings deal with proper grounding of equipment, use of solvents, etc. Ignoring warnings may damage the unit, and risk personal injury or even death to the Instrument Technician.

1.1 DESCRIPTION

The Moore Industries Linear Totalizer (LIT) accepts current or voltage input and produces a pulse signal that drives a totalizing counter. The output pulse can be scaled to represent gallons, barrels, BTU or any other engineering unit. The Model LIT is highly accurate because the unit features dual slope, continuous integration and digital ranging.

The LIT can be quickly and easily precision calibrated to within $\pm .05\%$ accuracy (with 0.1% repeatability) using three external calibration terminals for ZERO, SPAN and COUNT DROPOUT. The count dropout is adjustable from 0.5 to 20.0% of full scale. This eliminates false totalization of unwanted low level noise signals.

1.2 SPECIFICATIONS

Table 1-1 contains equipment specifications for the LIT. These specifications include options for inputs, outputs, housings and enclosures, and operational power. Also listed is environmental and equipment ordering information.

1.3 MODEL NUMBER EXPLANATION AND USE

MOORE INDUSTRIES model numbers identify the instrument type, functional characteristics, operating parameters, and any options ordered. If the documentation is missing, the model number can be used to obtain technical information of the unit.

On standard units and units with the -CP and -AB options, the model number is located at the upper end of the terminal block stamped on a stainless steel tag. Plug-in (-PC) units have the model number labeled on the inside of the grip extension to the front panel. Explosion-proof units (-EX) have the model number stamped on a stainless steel tag on top of the enclosure and on an identification label inside the housing. Panel mounted units (-PM option) have the model number stamped on a stainless steel tag that is visible when the rear safety cover is removed. To expose the model number on all NEMA enclosures, open the box and remove the safety cover of the unit.

The following graphic breaks down the LIT model number for configuration and options.

Table 1-1. LIT Specifications

Characteristics		Input Ranges (Continued)	Voltage:	Options (Continued)
Adjustments	22-turn potentiometers Zero: For an input of $\pm 10\%$ of maximum input range, adjusts output to 0% of selected output span. Span: With maximum selected input, output is adjustable to within \pm %.	Output Spans (In counts per hour)	0-5V, 1-5V standard 0.5 megohms minimum input impedance 0-100MV: 0-100mV (optional) Other voltages optional.	-HS Hermetically-sealed SPST relay rated at 1A @ 28Vdc, non-inductive (requires -RR or -RRNC option) -IT Integral bracket mounted 6-digit manual or non-reset totalizer (electro-mechanical) -PR Solid-state power relay, 5A @ 117Vac only, inductive; available only with following housings: GP; FG; OT; WT (not available with -RE or -RR option). -RE External relay rated at 5A @ 28Vdc or 117Vac, non-inductive (not available with -PC housing) -RF Patented filter assembly for RFI/EMI protection; exceeds SAMA std. PMC 33.1 1978 Class 2 a,b,c (not available with -PC or -PM housing). -RR SPST relay contact output, rated at 1A @ 28Vdc, non-inductive (NO standard - specify NC if required). -TX Two-wire transmitter excitation - 35Vdc at 25mA max. to power 4-20mA two-wire field transmitter.
Performance	Calibration Capability: $\pm 0.05\%$ of span (linearity) Repeatability: $\pm 0.01\%$ of span Line Voltage Effect: $\pm 0.005\%/1\%$ line voltage change (ac or dc)		(All ranges selected by internal dip switch) A3 0 to 12.5 thru 25 cph A2 0 to 25 thru 50 cph A1 0 to 50 thru 100 cph A 0 to 100 thru 200 cph B 0 to 200 thru 400 cph C 0 to 400 thru 800 cph D 0 to 800 thru 1600 cph E 0 to 1600 thru 3200 cph F 0 to 3200 thru 6400 cph G 0 to 6400 thru 12,800 cph H 0 to 12,800 thru 25,600 cph J 0 to 25,600 thru 51,200 cph Higher rates available on special order.	
Ambient Temperature	Range: -18°C to $+72^{\circ}\text{C}$ (0°F to $+165^{\circ}\text{F}$) Effect: $\pm 0.01\%/^{\circ}\text{F}$ over above range	Power Input	24DC 24Vdc $\pm 10\%$ 45DC 45Vdc $\pm 10\%$ 117Vac, 220Vac, 240Vac, 50/60Hz, $\pm 10\%$ 5 watts nominal	Housings
Output	24V, 35 millisecond output pulse compatible with external standard electronic or electromechanical totalizers; optional relay contact output available Count Dropout: 0.5% to 20% of input full scale (adjustable)	Options	-AT Attenuated input for signal input voltage exceeding standard specifications - specify voltage (200V max.) -ED6 Integral bracket mounted, 6 digit manual or electric reset, solid-state LCD counter -ED8 Integral bracket mounted, 8 digit electric reset, solid-state LCD counter -ET 12V output pulse for electronic counters other than -ED6 and -ED8 -EZX Elevated zero input (required for all inputs exceeding standard zero adjustment capability - specify input for 0% out) -FS Front mounted range selection switch (A3-J) -FT Front-mounted totalizer for PM housing -FU 400mA power fuse for -PC housing (requires engineering for STD housing)	STD Standard enclosure AB Angle bracket mounting CP Conduit plate for use with standard units D2 Conduit plate with special aluminum safety cover to meet Class I, Gp. A,B,C,D Div. 2 requirements EUR High-density plug-in Euro Card (int'l spec's) EX Explosion-proof enclosure, Single Unit - Div. 1 FG Fiberglass enclosure, Single Unit - NEMA 12 GP General-purpose enclosure, Single Unit - NEMA 1 OT Oiltight enclosure, Single Unit - NEMA 12 PC Plug-in card housing (24Vdc & 45Vdc power only) PM Panel mount enclosure TCE Transparent cover enclosure, Single Unit - NEMA 4 WT Watertight enclosure, Single Unit - NEMA 4
Isolation	Isolation between power and input-output is standard. Input-output isolation is achieved by specifying an optional relay output			
Certification	CSA			
Weight	Approximately 2 pounds (908 grams)			
Ordering Specifications				
Unit	LIT			
Input Ranges	Current: 1-5MA: 1-5mA into 200 Ω nominal 4-20MA: 4-20mA into 50 Ω nominal 10-50MA: 10-50mA into 20 Ω nominal			
When ordering, specify: Unit / Input Range / Output Span (A3-J) / Power Input / Options [Housing] Model number example: LIT/4-20MA/E/117AC/-RR -TX [STD]				

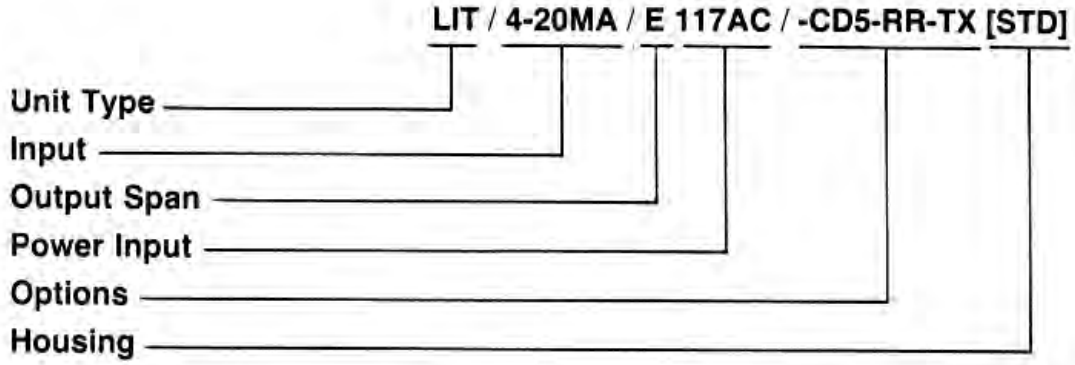

1.4 SERIAL NUMBER USE AND LOCATION

MOORE INDUSTRIES keeps a complete history on each unit sold. This historical information is keyed to the serial number. If service is required on a unit, it is necessary to provide the factory with the serial

number as well as the model number. This identification is usually located with the model number as described in paragraph 1.3. Plug-in units have the serial number engraved into the printed circuit board.

CALIBRATION PROCEDURES

2.0 CALIBRATION PROCEDURES

This section contains information necessary for unit adjustment and calibration. Each unit is adjusted and checked for proper performance at the factory before shipment. However, input and output values for each unit should be checked, on site, by the user before the equipment is placed into service. See paragraph 1.3 and the LIT specifications in table 1-1, section 1.0, for minimum and maximum inputs and outputs.

2.1 GENERAL INFORMATION

After a Linear Integrating Totalizer is unpacked, general operating level checks are recommended using the calibration procedures specified in this section. If units are ordered with factory calibration (-FC option), an exact calibration is performed at the factory and red caps are put over the controls. Adjustments should not be made in the field to the units with red caps unless a new range of input or output signals is desired.

2.2 CONTROL DESCRIPTION AND LOCATION

ZERO and SPAN adjustments are located on the front panel of the Model LIT. The external controls are 22-turn potentiometers that are adjusted with a blade screwdriver.

CAUTION

SCREWDRIVER BLADE MUST NOT BE MORE THAN 0.1 INCH (2.54MM) WIDE. USE OF A WIDE BLADE MAY PERMANENTLY DAMAGE THE POTENTIOMETER MOUNTING.

2.3 TEST EQUIPMENT AND TOOLS REQUIRED

The test equipment and tools required for calibrating the LIT are described in Table 2-1; they are not supplied and must be provided by the customer at the installation or test site.

2.4 TEST EQUIPMENT SET-UP

The test equipment set-up required to calibrate an LIT unit is shown in Figure 2-1. For plug-in units, the printed circuit board connections are shown in parentheses.

Note: In the explosion-proof (-EX option) housing, the protective housing must be opened and the unit removed to expose the connection block. Similarly, units with the -PT option must be unplugged from the connection block for better access.

2.5 CALIBRATION

LIT units are calibrated and checked for proper performance at the factory before they are shipped. However, unless calibration was requested to a specific set of input/output values, the performance of the unit should be checked by the user before the module is placed in service.

Calibration consists of simulating the operative signal input and adjusting the unit to obtain the specified output.

Note: Adjustments should not be made in the field to units that are calibrated at the factory to customer's specifications. Units calibrated in this manner have protective red caps over the SPAN and ZERO potentiometers.

An adjustable input signal source and input monitoring device are required for calibration. An electronic counter is also required to determine the output pulse rate.

2.5.1 Calibration of Unit Without -RR Option

To facilitate adjustment and calibration of the LIT module, three test points are brought out to the external terminal board. They are identified as CAL1, CAL2, CAL3 and are referenced to the -IN terminal.

CAL1 is monitored with the dc voltmeter while making the initial ZERO potentiometer setting to obtain approximately +7mV at this terminal with a 0% input signal. (This biases the analog signal input to the first integrator at the zero level to compensate for the live zero input.)

CAL2 brings out the -10V pulse count signal ahead of the divider, which scales the pulse rate to appropriate engineering units for the output signal. (Note: Monitor the event counter for internal display. This gives a faster, more accurate test reading than monitoring the output directly.)

CAL3 provides access to the count dropout comparator ($\pm 10V$ binary signal). This facilitates monitoring the count dropout potentiometer when adjusting for a specific input level.

Full Scale Output Count Rate: Connect the Model LIT and test equipment as shown in Figure 2-1. The Full Scale Output Count Rate is defined by the jumper installed per Table 2-3.

Initial Setting of the SPAN Potentiometer: Connect the electrical counter between CAL2 and the -IN terminal. Set the input signal to 100%. Using the appropriate scale factor from table 2-2, determine the interval at CAL2. Set the counter for "period" and adjust the SPAN potentiometer until the counter displays the correct period as calculated below.

$\frac{3600}{\text{CPH} \times K} \times 1000 = \text{Output Interval in milliseconds}$ <p style="margin: 0;">Where CPH = counts per hour (any range, any % input)</p> <p style="margin: 0;">K = scale factor per table 2-2</p>

Final Setting of the ZERO Potentiometer: Set the input to 25% of full SPAN and calculate the correct interval as four times (4X) the 100% input interval. Readjust the ZERO potentiometer to generate this interval on the counter display. Repeat the full scale and 25% of full scale input settings to the ZERO and SPAN potentiometers until no further adjustments are necessary.

Input and Output Tracking: Input and output tracking can be verified at any desired intermediate point by using the calculation above. The output should follow the calculated values to within 0.1% of full scale.

While monitoring the CAL3 terminal, adjust the input signal to the desired count dropout level and adjust the count dropout potentiometer to obtain -10Vdc at this level.

After all the preceding steps have been successfully completed, remove the input signal source and turn off the power to the unit.

2.5.2 Calibration of Unit With -RR Option

To calibrate an LIT that includes the -RR option, proceed the same as for a unit without the option because all measurements can be made at CAL1, CAL2 and CAL3 terminals. A functional test of the -RR contacts can be made using a simple continuity tester, if desired.

2.6 OUTPUT PULSE RATE RANGE

The output pulse rate can be changed in the field by modifying the jumper connections on the Pulse Rate printed circuit board (PC3 for standard units, PC2 for plug-in units) and the main board (PC1). See Table 2-3.

Table 2-1. Test Equipment and Tools Required

Equipment/Tool	Characteristic	Prupose
Screwdriver (flat-head)	Width no greater than 0.1 inches (2.54 mm)	Front panel control adjustment
Adjustable DC Signal Source	Must be capable of producing signal ranges defined by INPUT level requirements of purchased unit	Simulate input signal
DC Voltmeter	Must be accurate to within $\pm 0.05\%$ or better	Input signal monitoring (voltage inputs only)
DC Milliammeter	Must be accurate to within $\pm 0.05\%$ or better	Input signal monitoring (current inputs only)
Counter/Timer	Fluke Model 1952A or equivalent	Output signal monitoring

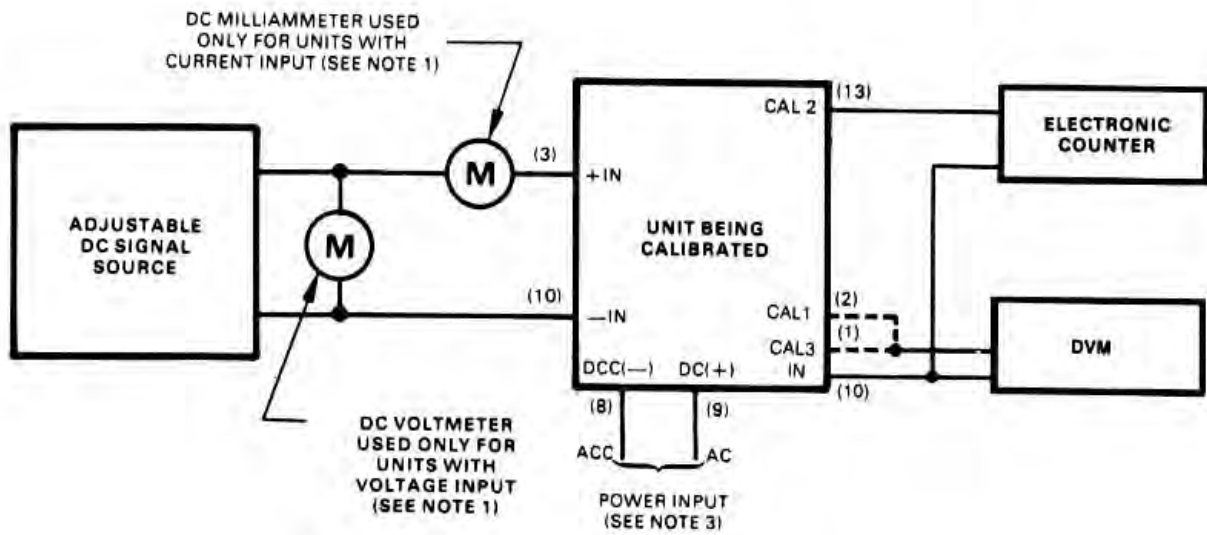

NOTES:

1. Input and output monitoring devices must be accurate to within $\pm 0.05\%$ or better.
2. Numbers in () refer to plug-in units terminals (see Figure 3-13).
3. Either AC power or DC power is supplied, but not both.
4. Do not connect DVM to CAL1 and CAL3 simultaneously.

Figure 2-1. Test Equipment Setup

Table 2-2. Scale Per Range Selection

OUTPUT RANGE	SCALE FACTOR
A1	512
A	256
B	128
C	64
D	32
E	16
F	8
G	4
H	2
J	1

Table 2-3. Field Selectable Output Pulse Rate Range

OUTPUT PULSE RATE RANGES	STD CIRCUIT MODIFICATIONS (PC3) *									
	J300	J301	J302	J303	J304	J305	J306	J307	J308	J309
A1									USED	
A								USED		
B							USED			
C						USED				
D					USED					
E				USED						
F			USED							
G		USED								
H	USED									
J										USED

BLANK SPACES: JUMPERS NOT USED OR COMPONENTS UNAFFECTED.

*Jumpers located on PC2 in Plug-in version

INSTALLATION & OPERATION

3.0 INSTALLATION AND OPERATION

3.1 MECHANICAL INSTALLATION

The Model LIT is available in several physical configurations. Installation details can be found on the Outline and Installation drawing contained in Section 6.0. Observe any special procedures and precautions given with the illustration.

Although the unit is designed for convection cooling, it is advisable to mount the unit on a surface made of material that can serve as a heat sink. The unit should be located in an area that is protected from dust, moisture, and corrosive atmospheres.

3.2 ELECTRICAL CONNECTIONS

Special wire or cable is not required for signal connections to the unit. To avoid transients and stray pick-ups, it is recommended that twisted conductors be used where they are run close to other services (such as power wiring). Electrical connections fall into two major categories: connections to all standard units with terminal blocks, and connections to plug-in units.

Standard Units: Standard units with terminal strips or terminal blocks have terminals supplied with 6-32 screws long enough to accommodate three spade-lug connectors. Standard units with snap-off plastic covers have an opening at the bottom of the cover; put all wires to and from the terminals through this opening. Spade-lug connectors are recommended for all wire terminations. See Table 3-1 for terminal nomenclature.

NEMA enclosures: Units mounted in NEMA boxes are standard units. Oil tight (-OT) or water tight (-WT) options do not have conduit holes, fittings or knockouts. Conduit access must be provided by fittings such as Myer Scru-Tite or equivalent. General purpose (-GP) enclosures have conduit knockouts from 1/2 to 1-inch. Corrosion-proof (-FG) enclosures require special attention with ground connections. Because the enclosure material is polyester resin, ground continuity may be obtained in two different ways. If a metal panel is used, ground can be made between the metal conduit locknut and the panel. If the enclosure is used without a back panel, a jumper between the conduit entry and exit is necessary to maintain ground continuity. Remove snap-off plastic cover to access terminal strips.

Plug-in Units: Plug-in units and card rack electrical connections are made to terminals on the mating connector for the unit or card rack terminal strips. See Table 3-2 for the terminal nomenclature.

3.2.1 Power Connections

LIT units operate from either a dc or an ac power source. Refer to your model number on the unit and paragraph 1.3 to determine the type of power required.

DC Powered Units: The DC terminal is connected to the + (positive) side of the power source; the DCC terminal is connected to the - (negative) side. The dc source should be regulated to within $\pm 10\%$ of the nominal voltage and should be capable of delivering 5 watts.

AC Powered Units: The AC terminal is connected to the ungrounded or "hot" side of the power source; the ACC terminal is connected to Common or neutral. The GND terminal is the mechanical case connection. These units require 117Vac, $\pm 10\%$, 50/60Hz at 5Va of nominal power or 220/240Vac optionally.

Rack Power Connections: Connect power input wires to the appropriately labeled terminals of the 3-terminal connector strip. The third terminal on the strip is chassis ground.

3.2.2 Connections on Units With The -SC Option

For units with the selectable current option (-SC), connect the input selectable current resistor to the +IN and -IN terminals. The current range is marked on the body of each resistor. If provided, the selectable current resistors for a plug-in unit should be mounted externally either at the terminal block of the card rack or soldered to the appropriate terminals on the PC connector. See Table 3-2 for correct connections.

3.2.3 Connections on Units With The -TX Option

For units with the -TX option, connect the positive output lead from the external equipment to the +TX terminal on this unit. Connect the minus output lead from the external equipment to the +IN input on this unit.

Table 3-1. Standard Unit Terminal Nomenclature

Options	Terminal Positions											
	1	2	3	4	5	6	7	8	9	10	11	12
NONE	CAL 1	CAL 2	CAL 3	DCC	DC	GND			+IN	-IN	+OUT	-OUT
AC	CAL 1	CAL 2	CAL 3	ACC	AC	GND			+IN	-IN	+OUT	-OUT
SC (input) (Note 2)												
TX							+TX					
RR							NO	COM				
RRNC							COM	NC				

NOTES:

- Labeling shown here may be combined. The combination may include standard labeling and one or more options. Combinations of options may cause labeling positions to change, but nomenclature will remain as shown.
- SC resistor is connected across \pm IN terminals.

Legend:

DC	+DC Power Input	ACC	AC Power Return	SC	Selectable Current Resistor
DCC	-DC Power Input	+TX	External Excitation Power Output	RR	Internal Relay, Normally Open Contact
GND	Chassis Ground	\pm OUT	Signal Output	RRNC	Internal Relay, Normally Closed Contact
AC	AC Power Input			COM	Relay Common

Table 3-2. Plug-in Unit and Card Rack Terminal Nomenclature

Options	Terminal Position														
	1	2	3	4	5	6	7	8	9	10	11	12	13	14	15
NONE	CAL 3	CAL 1	+IN	+OUT			-OUT	DCC	DC	-IN			CAL 2		
SC (Input) (Note)															
TX					+TX										

NOTE: SC Input resistor is mounted across -IN and +IN terminals.

Keyways

Legend:

DC	+DC Power Input	\pm IN	Signal Input
DCC	-DC Power Input	\pm OUT	Signal Output
GND	Chassis Ground	SC	Selectable Current Resistor
+TX	External Excitation Power Output		

THEORY OF OPERATION

4.0 THEORY OF OPERATION

This section describes the operation of Model LIT. The functional description is based on the unit block diagram, Figure 4-1. A detailed schematic diagram is located in Section 6.0, Unit Documentation.

4.1 FUNCTIONAL DESCRIPTION

The input signal for the Model LIT is first converted to a dc voltage proportional to the amplitude of the applied input signal. The voltage is then applied to a linear frequency converter, which produces output pulses at a rate linearly proportional to the amplitude of the input signal.

The output pulses from the unit can drive an external totalizer (counter) directly, or an optional relay may be used for this purpose. The zero dropout circuit prevents noise, zero offset errors, etc. from producing spurious counts with a signal level near 0% (i.e., eliminates counting when the signal is below 0.5 to 1% above the minimum input). A potentiometer is provided to adjust the exact point of dropout.

4.2 POWER SUPPLY CIRCUIT DESCRIPTION

Units are usually supplied for use with either an ac or dc power input. On units with an ac power input, the power supply typically develops a 24-volt dc output that is applied to the input of the power inverter. On units with a dc power input, the power is applied directly to the input of the power inverter, with diode protection to prevent damage to the power inverter components if the dc power input is accidentally connected with reversed polarity.

4.3 POWER INVERTER CIRCUIT DESCRIPTION

The power inverter produces a number of outputs from the dc applied to its input. Two separate square-wave outputs at approximately 3KHz are developed. A set of regulated positive and negative dc outputs are reduced and used as operating voltages for the unit. The inverter also produces a positive dc output as the operating voltage for the power amplifier. A 400 milliamp fuse (-FU option) placed in series with the +DC input protects the unit from damage where dc voltage may fluctuate enough to cause excessive current drain on the unit.

4.4 RECTIFIER AND REGULATOR CIRCUITS

The rectifiers accept the outputs from either the ac power supply or the power inverter and produce unregulated positive and negative voltages (of equal value with respect to ground). Two regulators reduce these voltages to the required operating values and regulate them against changes with load or line voltage variations. Another rectifier produces a higher unregulated output that is used as operating voltage for the -TX option.

4.5 INPUT NETWORK AND ZERO ADJUST CIRCUITS

The input signal is provided with the proper termination by the input network and is combined with the voltage from the zero adjust circuit. The zero adjust circuit adds an adjustable positive voltage to cancel the live zero of the basic input signal. With a low value input signal applied, the zero adjust circuit is adjusted so the voltage added to the applied input signal results in a zero count rate. Zero adjust voltage is provided to the inverting input amplifier while the incoming signal is connected directly to the non-inverting input to the amplifier.

4.6 INPUT AMPLIFIER CIRCUIT

The input amplifier increases the level of the composite input signal. No inversion takes place in this amplifier. The output of the amplifier drives the next stage, which is an inverter. The output is also applied to one input of the coupling network that supplies the signal to the integrator. High stability of the amplifier is achieved through the use of feedback.

4.7 INVERTER CIRCUIT

The output from the input amplifier is applied to the inverter, which has a gain of unity and produces an output with a polarity opposite to that of the input applied to this stage. The inverter provides one of the two signals of opposite polarity required by the coupling network that applies a signal to the integrator (the other signal to the network is provided by the input amplifier). Feedback is used in the inverter to achieve high stability and also to establish the gain.

4.8 INTEGRATOR-COMPARATOR CIRCUITS

The integrator-comparator combination produces, as the comparator output, pulses at a rate proportional to the amplitude of the input signal.

4.9 ONE-SHOT GENERATOR CIRCUIT

Since the duration of the pulses produced by the comparator varies with the pulse rate, the pulses must be converted to an output of constant duration. The one-shot generator accepts the basic or divided pulses and produces a 35 millisecond output pulse for each pulse received.

4.10 POWER AMPLIFIER CIRCUIT

The one-shot generator produces output at a low power level. To drive a counter or a relay, the pulses must be amplified. A two-stage power amplifier produces output pulses with enough power to drive either an external counter or an optional internal relay.

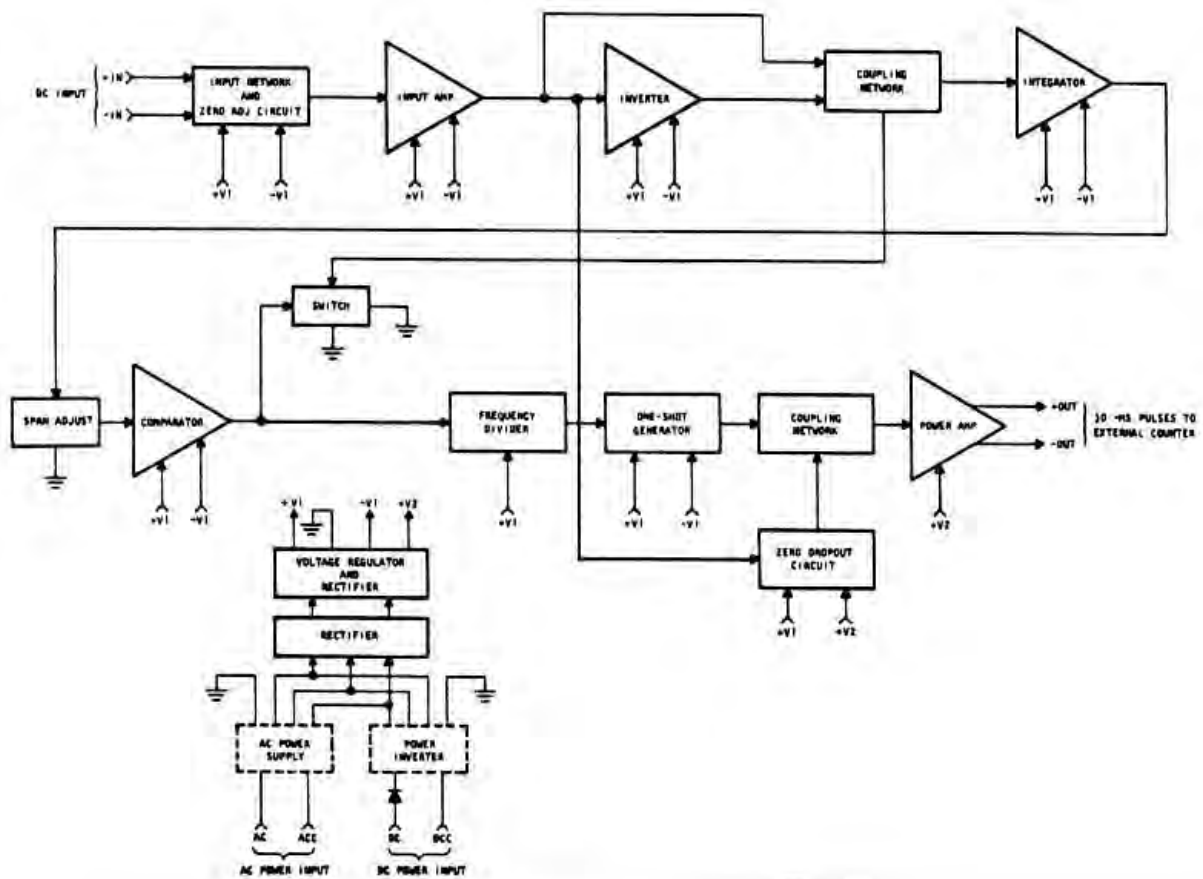

Figure 4-1. LIT Block Diagram

MAINTENANCE & TROUBLESHOOTING

5.0 MAINTENANCE AND TROUBLESHOOTING

All units found to be performing below specifications should be returned to the factory for service in accordance with the instructions found on the inside back cover of this manual.

In an emergency, the user may contact the Customer Service department for verbal assistance in diagnosing and repairing a totalizer problem.

5.1 MAINTENANCE

The design of the Model LIT totalizer limits maintenance primarily to keeping the input and output terminals and conductors clean and tight while maintaining a heat conduction path to a suitable heat sink. A thorough cleaning of terminal blocks for standard units and contacts for the plug-in modules requires complete disassembly and should only be done at the factory. It is recommended that the user check the terminations every six months of service to verify that they are secure and free of oxidation.

5.2 TROUBLESHOOTING

If a problem is suspected with the Model LIT totalizer, review the following procedures:

1. Verify that all electrical connections are clean and tight.
2. Verify that the measuring instrument used for input voltage or current is of the proper range and accuracy.
3. Verify that the output circuit is electrically isolated from the input circuit.

If the problem still exists, the unit might be defective and should be returned to the factory for repair in accordance with the instructions found on the inside back cover of this manual.

Table 5-1. Waveforms and Voltages

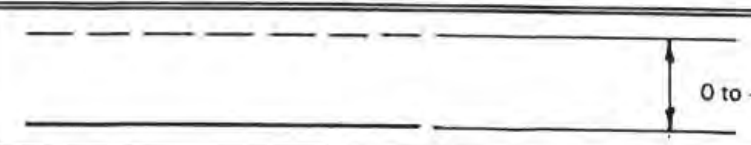
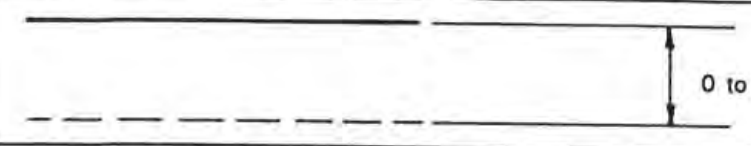
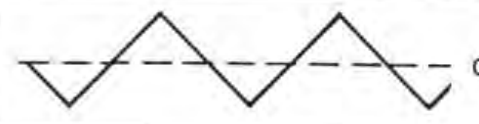
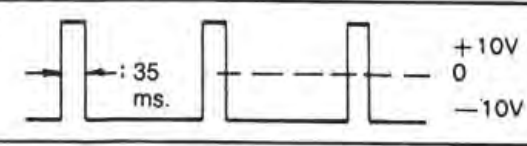
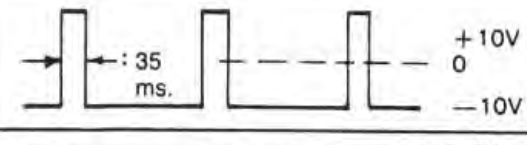
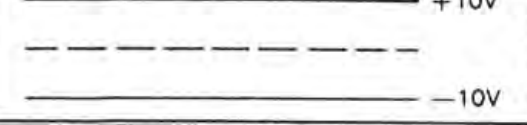
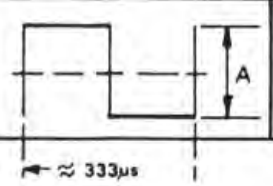
TEST POINT	WAVE FORM AND VOLTAGE LEVEL		
1		0 to -5V	
2		0 to +5V	
3		0 AMPLITUDE VARIES WITH SPAN ADJUSTMENT	
4		+10V 0 -10V	
5		+10V 0 -10V	
7		+10V 0 -10V IF INPUT IS ABOVE ZERO DROPOUT IF INPUT IS BELOW ZERO DROPOUT	
TEST POINT	WAVE FORM	POWER INPUT & WAVE FORM AMPLITUDE	
		24VDC/117VAC 220VAC/240VAC	45VDC
A		48V	90V

NOTES:

1. TP6 has been omitted intentionally.
2. T.P.A. is collector of Q401 and Q402 and referenced to DCC (COM) DC only

UNIT DOCUMENTATION

6.0 DRAWINGS

This section contains the drawings necessary to install, configure, and maintain the LIT unit. Outline drawings for the standard unit and plug-in card are provided here

for installation purposes. Also illustrated in this section are the schematic diagrams and relevant assembly drawings. Refer to table 1-1, section 1.0, for unit specifications.

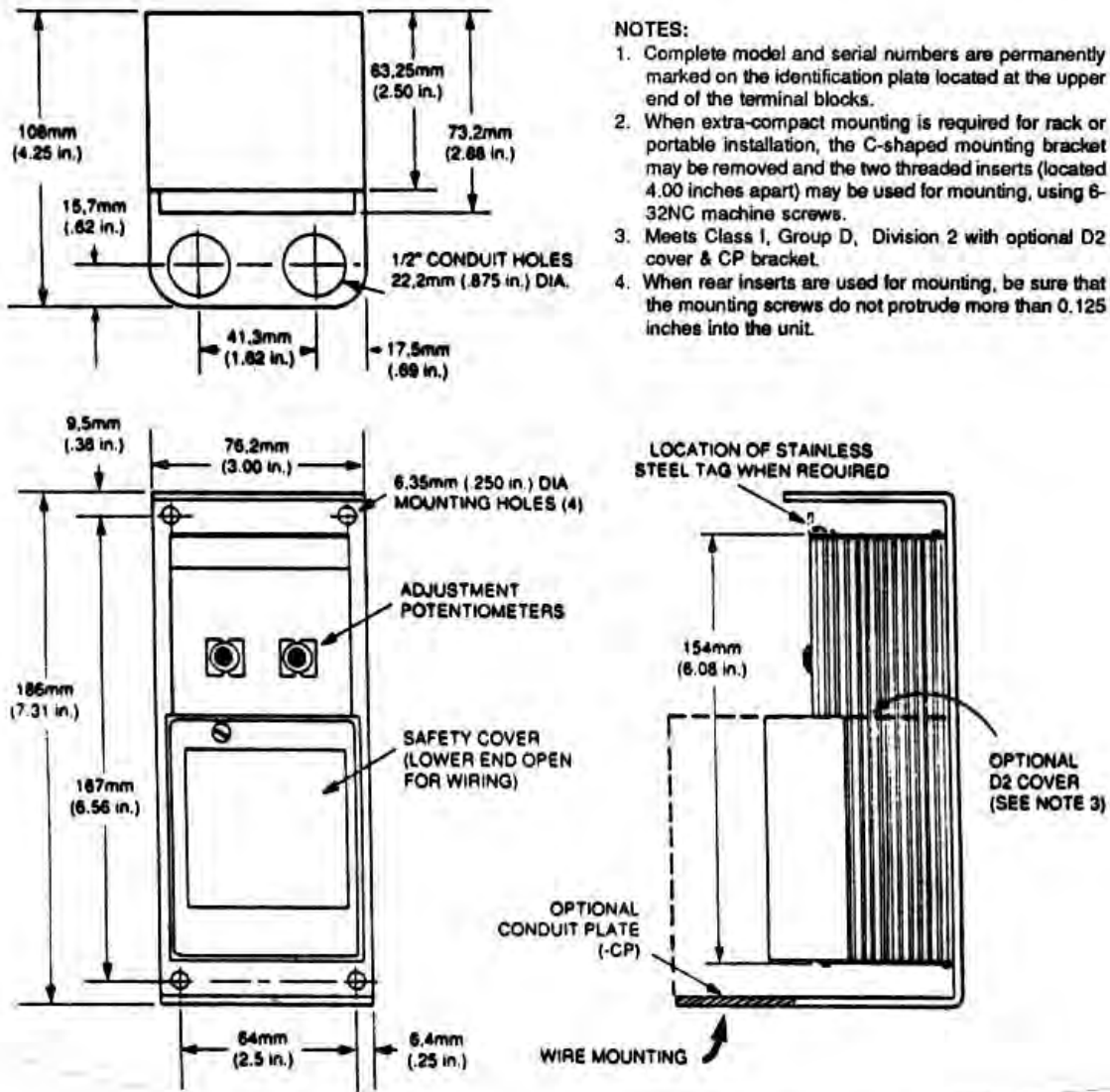

NOTES:

1. Complete model and serial numbers are permanently marked on the identification plate located at the upper end of the terminal blocks.
2. When extra-compact mounting is required for rack or portable installation, the C-shaped mounting bracket may be removed and the two threaded inserts (located 4.00 inches apart) may be used for mounting, using 6-32NC machine screws.
3. Meets Class I, Group D, Division 2 with optional D2 cover & CP bracket.
4. When rear inserts are used for mounting, be sure that the mounting screws do not protrude more than 0.125 inches into the unit.

Figure 6-1. Standard Unit Dimensions

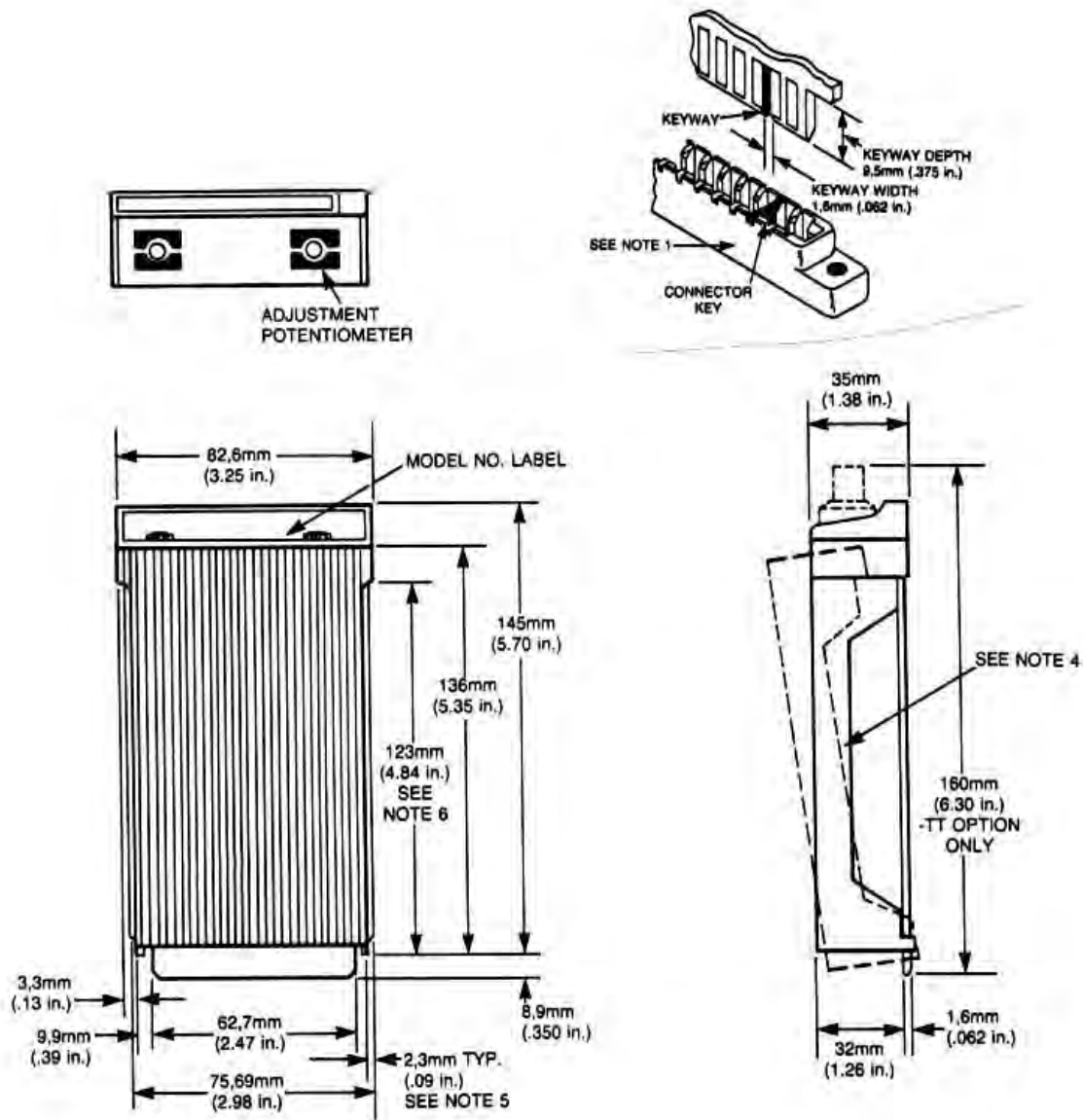

NOTES:

1. Connectors must have contacts on 3.96mm (.156 in.) centers, with contacts for both surfaces of board (recommended type: Viking part no. 2VK155/1-2).
2. Maximum card insertion depth in connector is 8.89mm (.350 in.).
3. Minimum width of connector insertion slot is 62.70mm (2.470 in.).
4. Removable plastic safety cover, 71.12mm (2.80 in.) wide. To remove safety cover, spread forward locking feet and lift front end approximately 1/4" inch; then slide cover to rear to disengage from card.
CAUTION: DO NOT LIFT FRONT END HIGHER THAN 1/4" OR TABS AT CONTACT END WILL BREAK.
5. Maximum card edge-guide insertion depth is 2.29mm (.09 in.). Guides must be non-conductive.
6. Card edge-guides cannot extend beyond point indicated.
7. Card extender part No. 350-513-00 is available for testing transmitter while in operating position.
8. Certified: CSA
9. All PC units are dc powered.

Figure 6-2. Plug-in Unit Dimensions

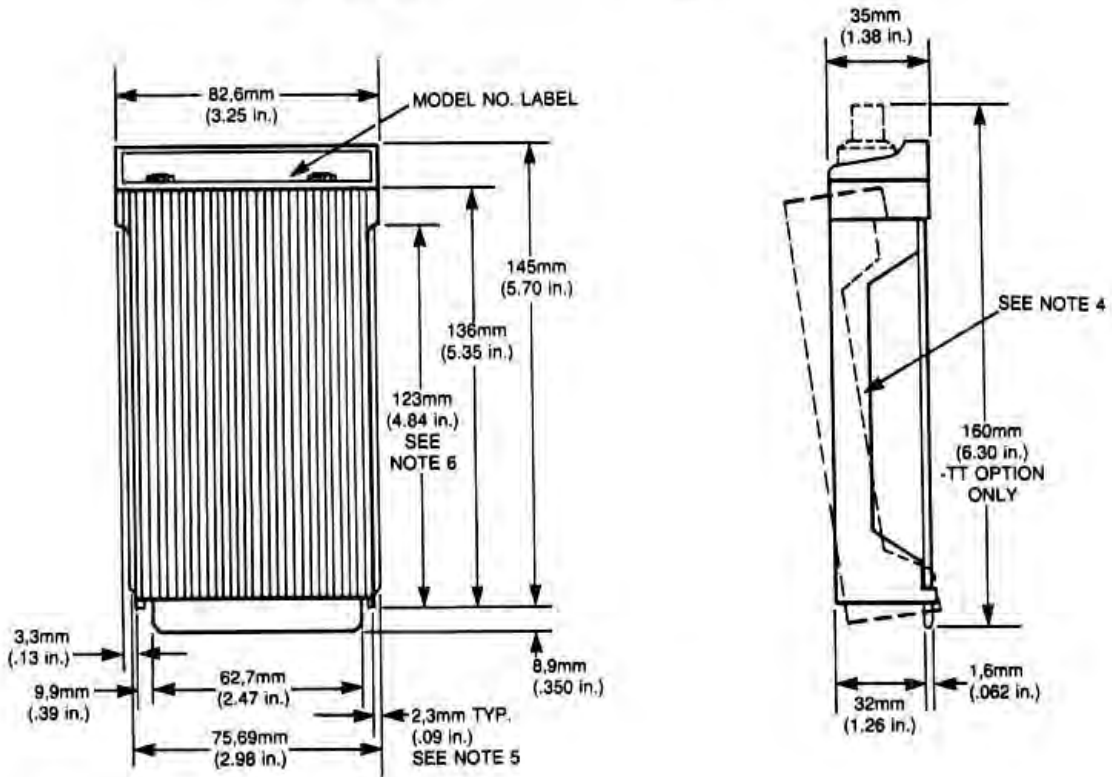
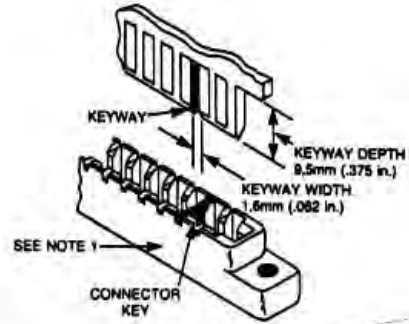
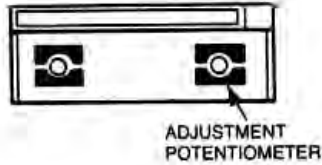

NOTES:

1. Connectors must have contacts on 3.96mm (.156 in.) centers, with contacts for both surfaces of board (recommended type: Viking part no. 2VK155/1-2).
2. Maximum card insertion depth in connector is 8.89mm (.350 in.).
3. Minimum width of connector insertion slot is 62.70mm (2.470 in.).
4. Removable plastic safety cover, 71,12mm (2.80 in.) wide. To remove safety cover, spread forward locking feet and lift front end approximately 1/4" inch; then slide cover to rear to disengage from card.
CAUTION: DO NOT LIFT FRONT END HIGHER THAN 1/4" OR TABS AT CONTACT END WILL BREAK.
5. Maximum card edge-guide insertion depth is 2,29mm (.09 in.). Guides must be non-conductive.
6. Card edge-guides cannot extend beyond point indicated.
7. Card extender part No. 350-513-00 is available for testing transmitter while in operating position.
8. Certified: CSA
9. All PC units are dc powered.

Figure 6-2. Plug-in Unit Dimensions

MOORE INDUSTRIES
 16650 Schoenborn Street
 Sepulveda, California 91343

DO NOT SCALE DRAWING	
TOLERANCES UNLESS NOTED	DATE: 12/1/78
X ±.1	DESIGNED BY: [Signature]
XX ±.03	ENGINEER:
XXX ±.010	SCALE: 2/1
ANGLES ±30'	

STANDARD LIT, PCI

DRAWING NUMBER: 197-501-00	REVISION: V
CATEGORY: ASSEMBLY	
REVISED BY: ECO 5732	DATE: 3/7/75
	BY: JAD
	APPROVAL: [Signature]

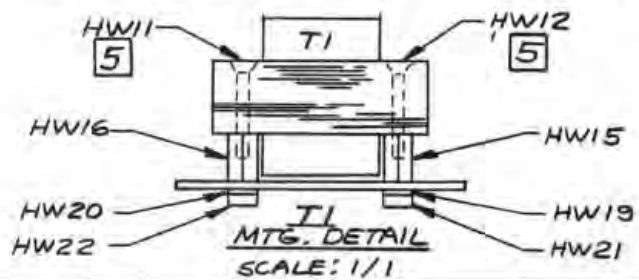
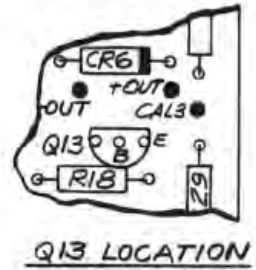
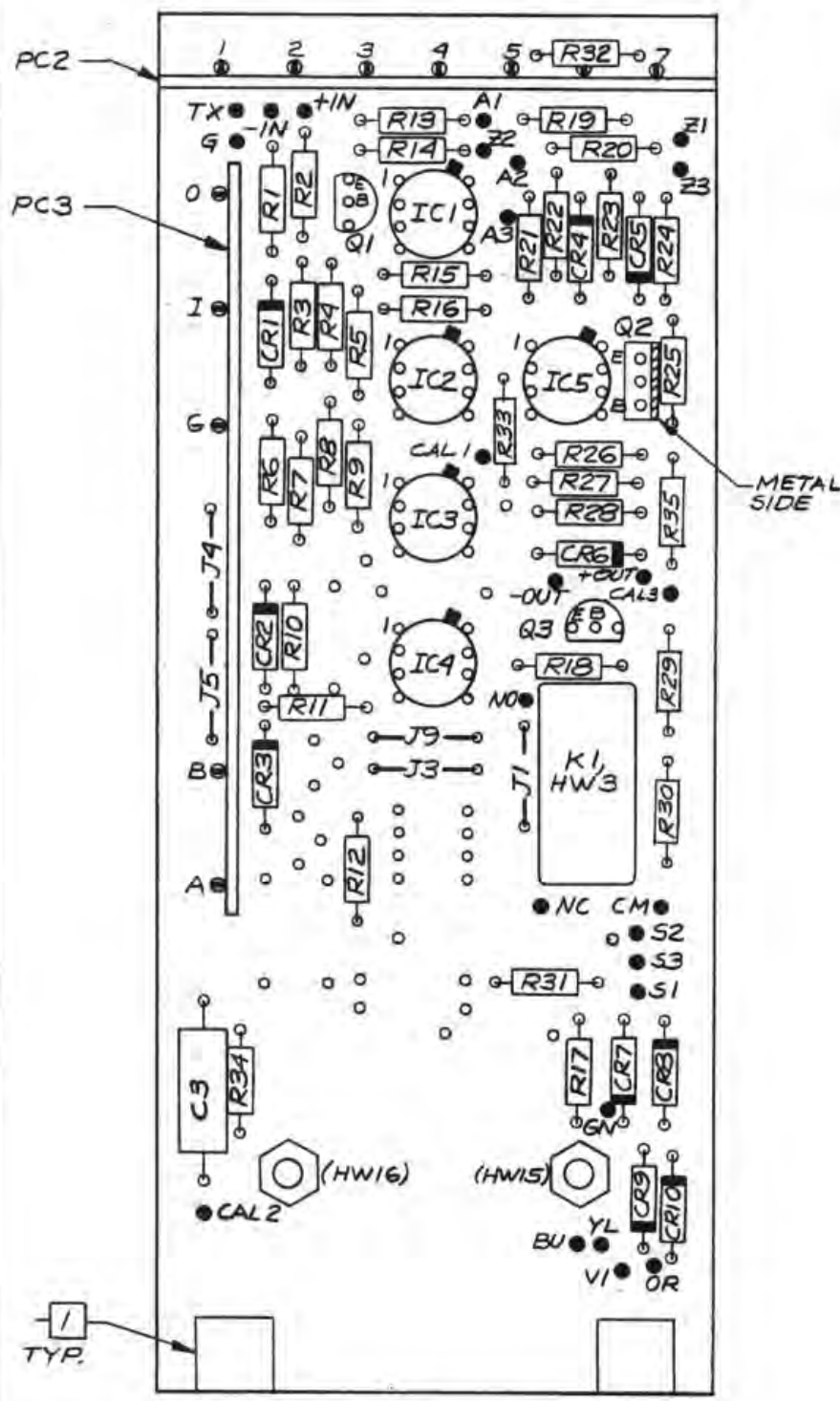

- NOTES -
- 5 APPLY "LOK-TITE" TO THREADS OF HW11 & HW12.
 4. SEE SHT. 2 FOR MTS. OF VS1, VS101 & R101.
 3. ALL LEADS & TERMINALS MUST BE SOLDERED TO PADS.
 2. ALL JUMPERS ARE 22AWG BUSS, TEFLON SLEEVED AS REQ'D.
 1. INSTALL MTS. BLOCKS BEFORE STARTING BD. ASS'Y; SEE CASE ASS'Y FOR LOCATION.

MOORE INDUSTRIES
 18650 Schoenborn Street
 Sepulveda, California 91343

DO NOT SCALE DRAWING
 TOLERANCES UNLESS NOTED
 X ±.1
 XX ±.03
 XXX ±.010
 ANGLES ±30'
 DRAWN: *A. Haddock* 12/21/80
 CHECKED:
 ENGINER:
 SCALE: 2/1

**STANDARD
 LIT,
 PCI**

DRAWING NUMBER: **197-501-00**
 CATEGORY: **ASSEMBLY**
 REVISED BY: **ECO 5732**
 DATE: **3/2/85**
 BY: **JAD**
 APPROVAL: *[Signature]*

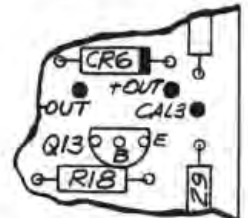
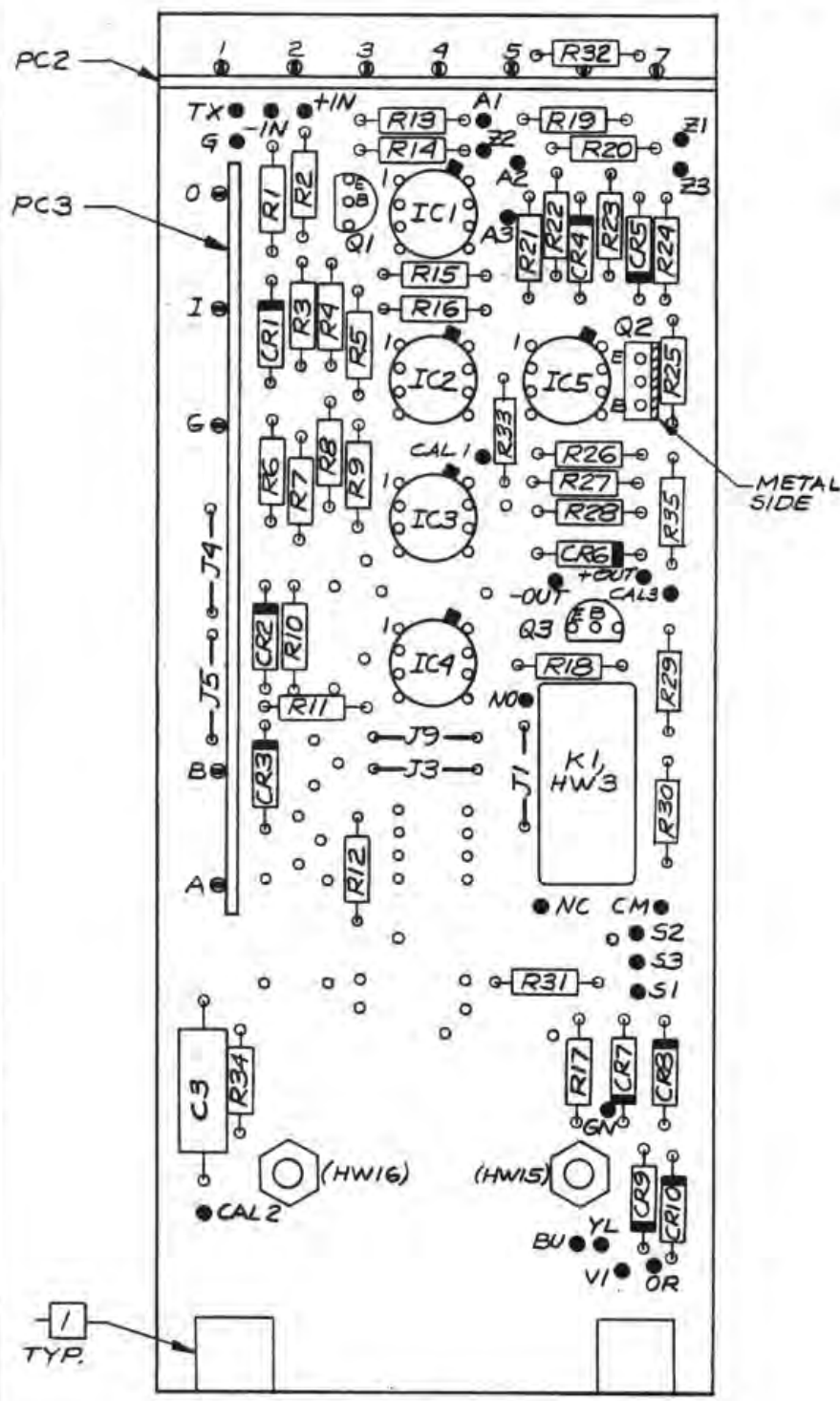

Q13 LOCATION

METAL SIDE

1
TYP.

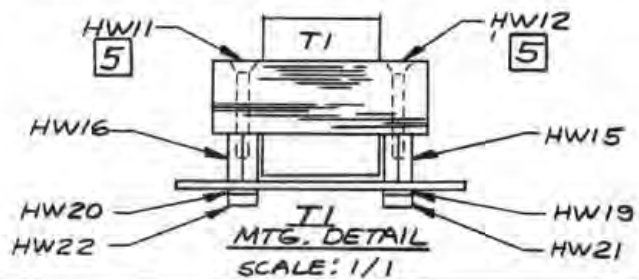

- 5 APPLY "LOKXTITE" TO THREADS OF HW11 & HW12.
 - 4. SEE SHT. 2 FOR MTG. OF VS1, VS101 & R101.
 - 3. ALL LEADS & TERMINALS MUST BE SOLDERED TO PADS.
 - 2. ALL JUMPERS ARE 22AWG BUSS, TEFLON SLEEVED AS REQ'D.
 - 1 INSTALL MTG. BLOCKS BEFORE STARTING BD. ASS'Y; SEE CASE ASS'Y FOR LOCATION.
- NOTES -

REVISION **V**
 DRAWING NUMBER **197-501-00**
 CATEGORY **ASSEMBLY**
 DATE BY APPROVAL

ADDITIONAL PARTS LOCATION, STANDARD LIT (PCI)

DO NOT SCALE DRAWING
 DRAWN **C. A. LEWIS** 12/1/81
 CHECKED
 ENGINEER
 SCALE **1/1**
 TOLERANCES UNLESS NOTED
 .X ±.1
 .XX ±.03
 .XXX ±.010
 ANGLES ±30'

MOORE INDUSTRIES
 16650 Schoenborn Street
 Sepulveda, California 91343

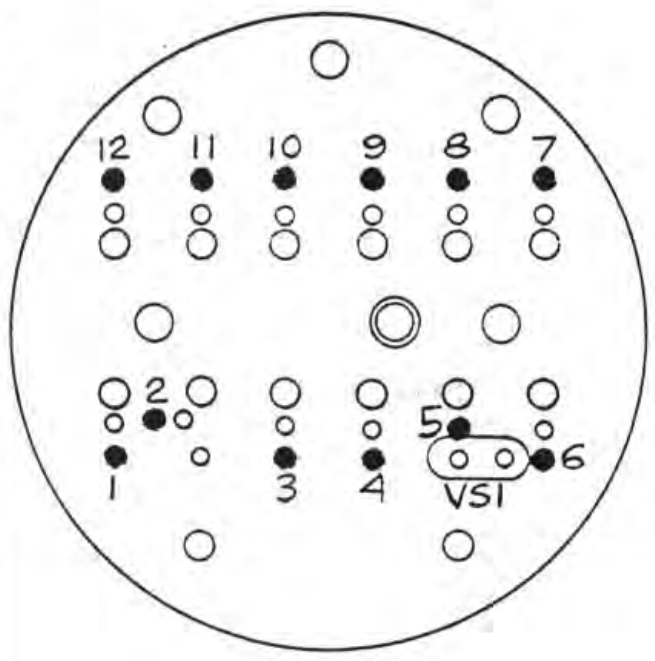

VSI

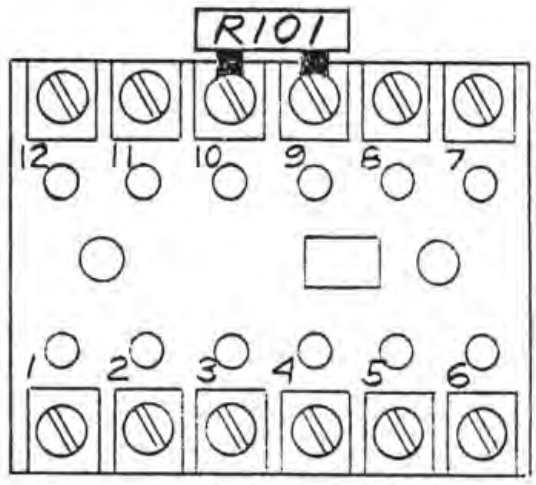

R101

"SP" ONLY

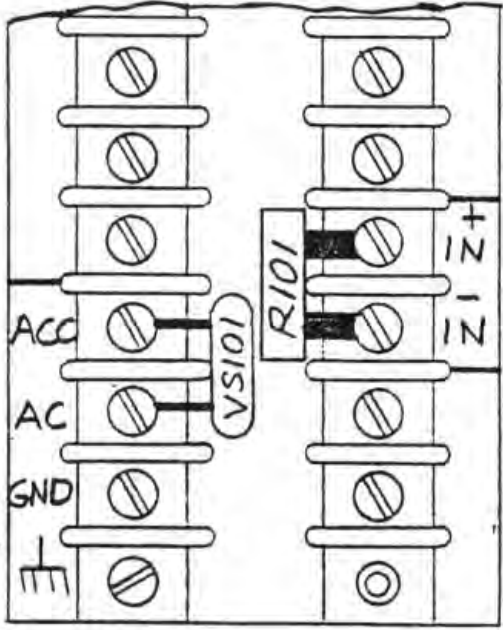

VSI01, R101

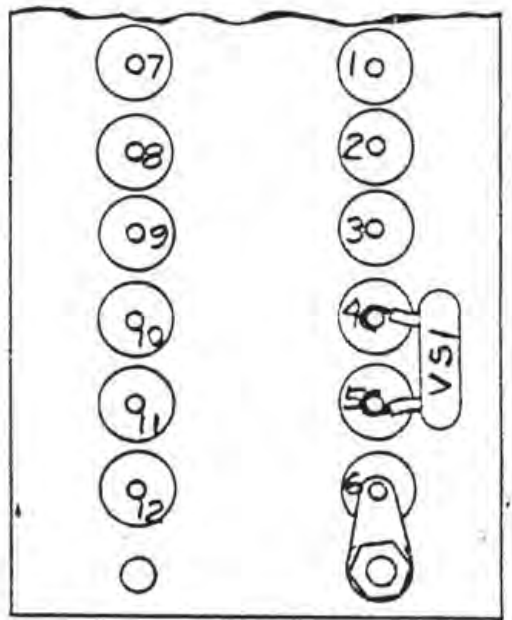

VSI

"SR" ≠ "CH" ONLY

TOLERANCES UNLESS NOTED	DATE: 10/1/82
X ± .1	CHECKS:
XX ± .03	FRONT:
XXX ± .010	SCALE: 2/1
ANGLES ± 30°	

P.C. BOARD ASSY
 STANDARD
 LIT
 (PC3)

DRAWING NUMBER: 197-502-00

ASSEMBLY

REVISED BY: ECO 6667

REVISION: L

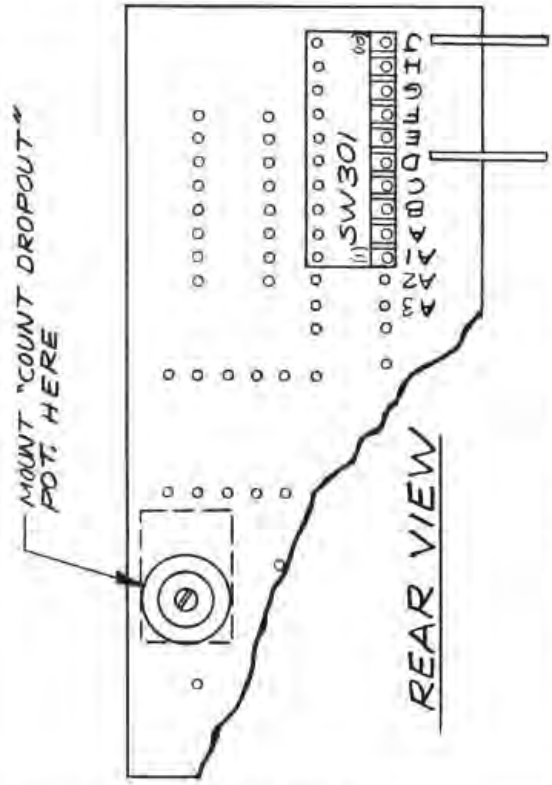

RELOCATE SW301 TO CASE ASSY
 POT. AS SHOWN IN CASE ASSY

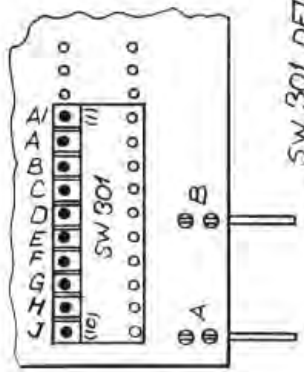
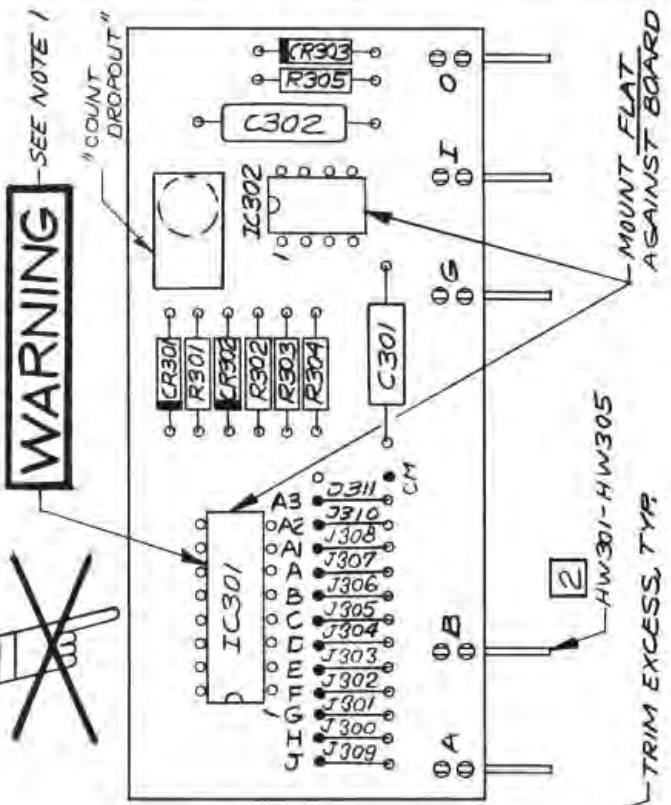

SW 301 DETAIL

2 INSTALL HW301-HW305 FLAT ON BOARD.

1. DO NOT TOUCH LEADS OF IC301 WITH FINGERS UNTIL SOLDERED TO BOARD. USE A LOW-VOLTAGE GROUNDED SOLDERING IRON.

NOTES-

REV: 1
 DRAWING NUMBER: 197-507-00
 CATEGORY: ASSEMBLY
 DATE: 9/2/81
 BY: C.F.
 APPR: [Signature]
 REVISED BY: ECO 4577

DC/AC INVERTER,
 STD. LIT
 (PC4)

DO NOT SCALE DRAWING
 DRAWN: C. FIEDERER 12/1/81
 CHECKED: [Blank]
 ENGINEER: [Blank]
 SCALE: 2/1
 TOLERANCES UNLESS NOTED:
 .X ±.1
 .XX ±.03
 .XXX ±.010
 ANGLES ±30°

MOORE INDUSTRIES
 16650 Schoenborn Street
 Sepulveda, California 91343

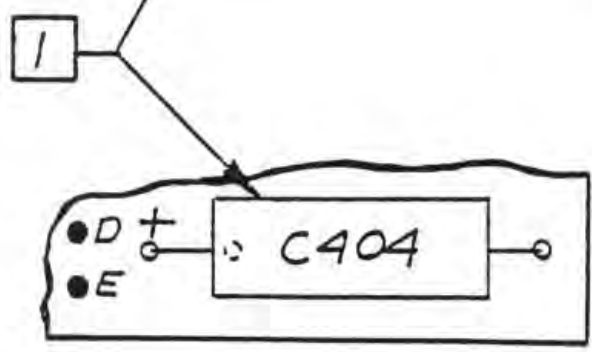
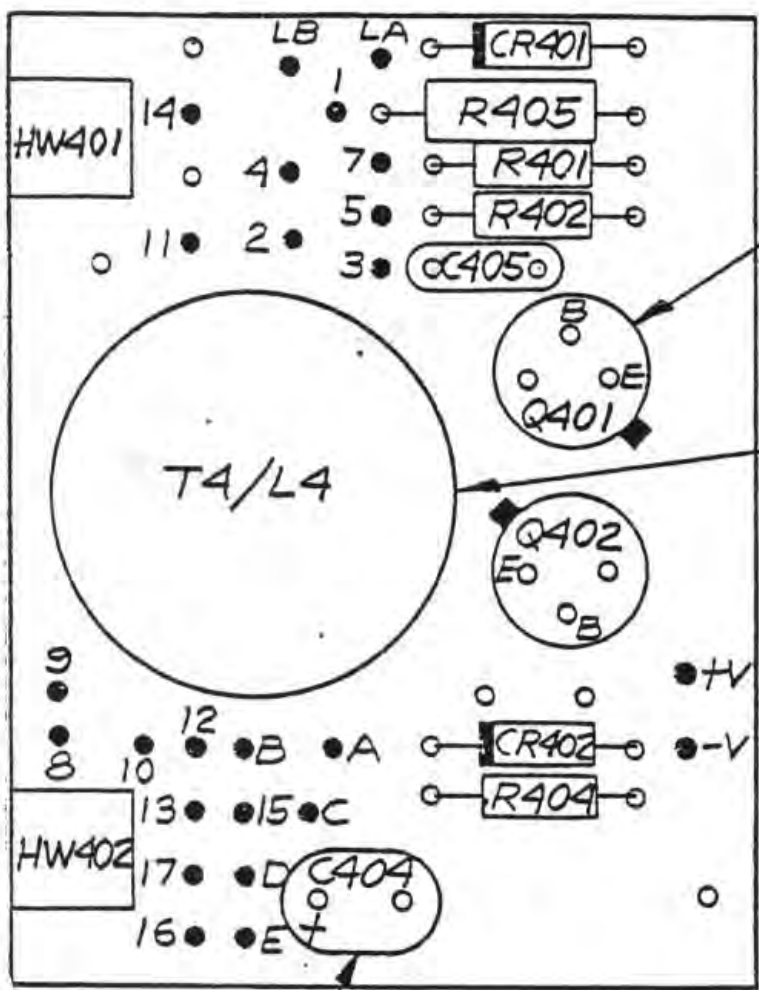

1 CHOOSE MTG. POS'N WHICH MATCHES PART.
 NOTES -



MOORE INDUSTRIES
18450 Schoenborn Street
Sepulveda, California 91343

DO NOT SCALE DRAWING

TOLERANCES
UNLESS NOTED
X ±.1
.XX ±.03
.XXX ±.010
ANGLES ±30°

DESIGNED BY TESSER 2/17/77
CHECKED BY [Signature] 2/21/77
DATE 2/17/77
SCALE 2/1

POWER SUPPLY
REGULATOR
(P.C. 2)

197-500-00 C

ASSEMBLY

REVISED BY ECO 3519

DATE 3/6/77
BY [Signature]
APPROVED BY [Signature]

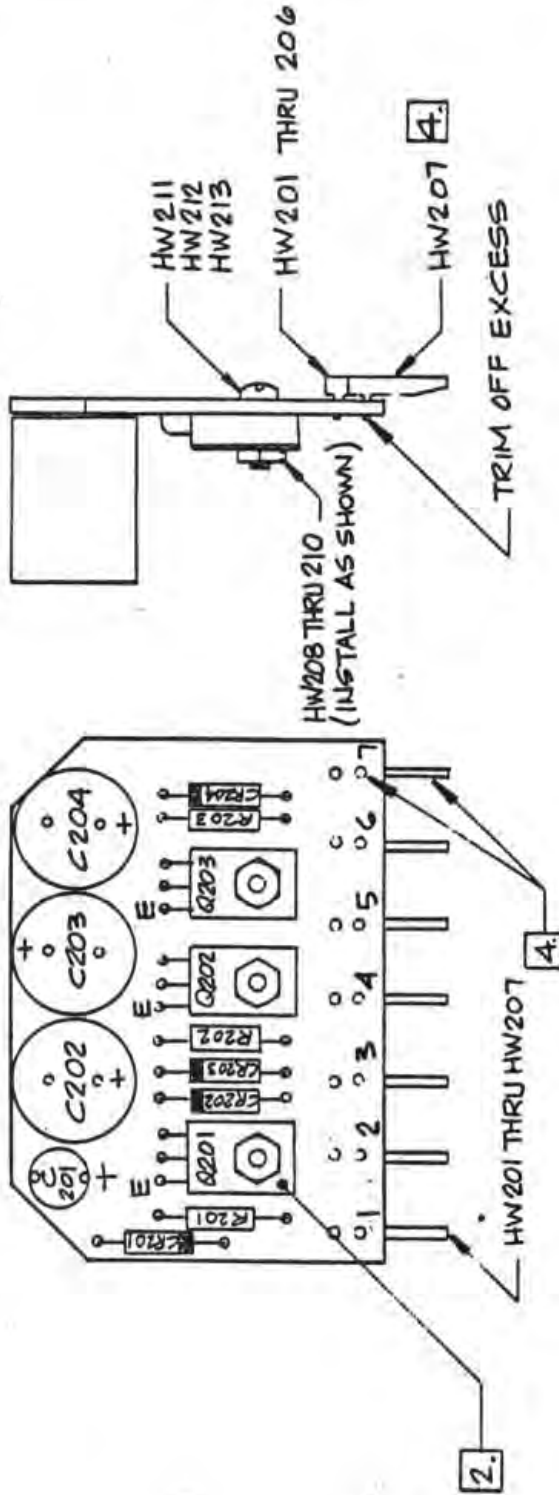

- 4. CUT HW207 BETWEEN TWO UPPER SOLDER PINS & REMOVE UPPER PORTION PRIOR TO INSERTING & SOLDERING IN BOTTOM HOLE. KEEP TOP HOLE FREE OF SOLDER.
 - 3. FOR SCHEMATIC SEE DRAWING: 197-401-00.
 - 2. METAL SIDE OF Q201, Q202 & Q203 TO FACE UP; (AWAY FROM BOARD).
1. ALL LEADS MUST BE SOLDERED TO PADS.
- NOTES: UNLESS OTHERWISE SPECIFIED

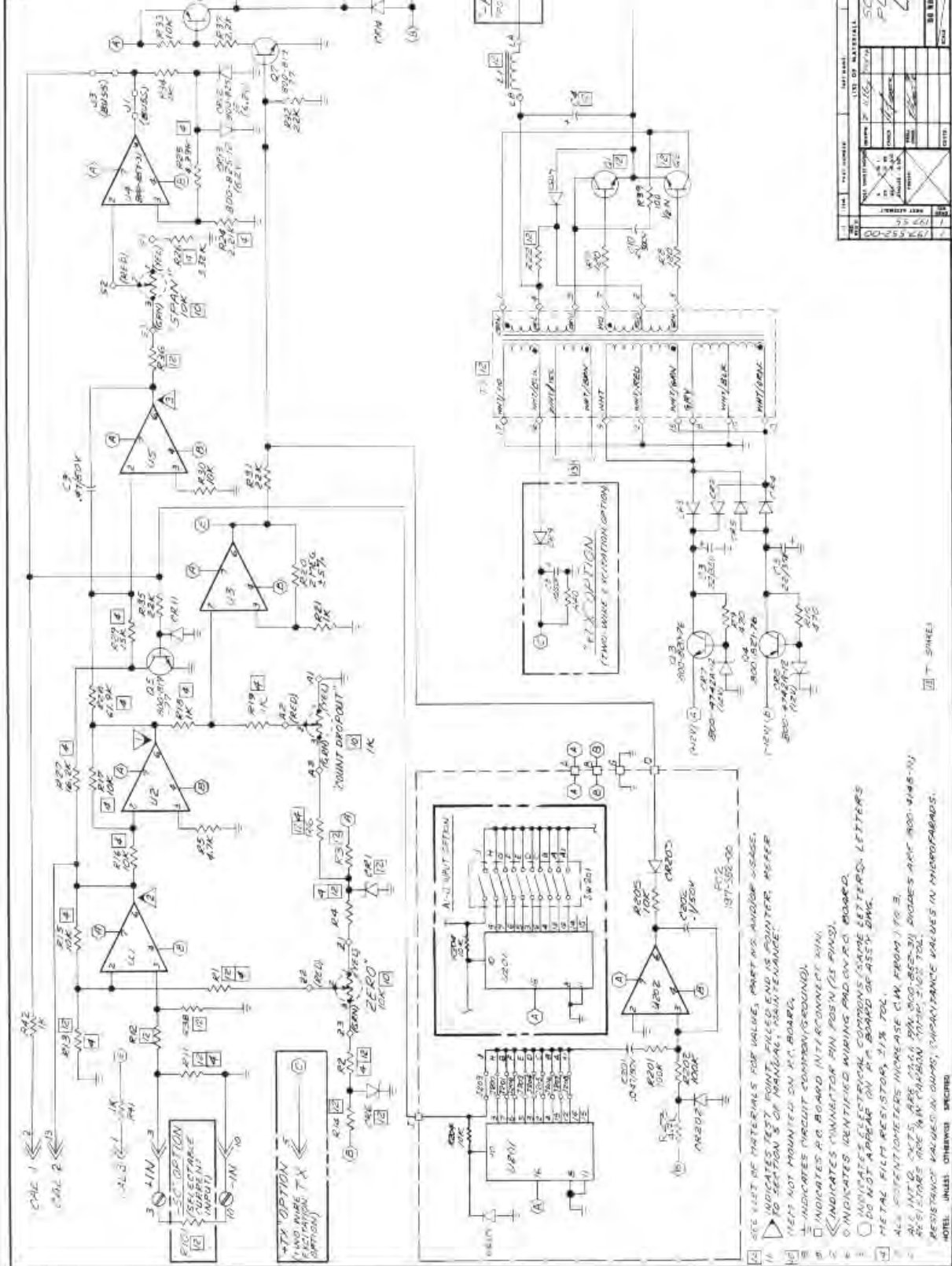

REV. 1	REV. 2	REV. 3	REV. 4	REV. 5	REV. 6	REV. 7	REV. 8	REV. 9	REV. 10
REV. 11	REV. 12	REV. 13	REV. 14	REV. 15	REV. 16	REV. 17	REV. 18	REV. 19	REV. 20
REV. 21	REV. 22	REV. 23	REV. 24	REV. 25	REV. 26	REV. 27	REV. 28	REV. 29	REV. 30
REV. 31	REV. 32	REV. 33	REV. 34	REV. 35	REV. 36	REV. 37	REV. 38	REV. 39	REV. 40
REV. 41	REV. 42	REV. 43	REV. 44	REV. 45	REV. 46	REV. 47	REV. 48	REV. 49	REV. 50
REV. 51	REV. 52	REV. 53	REV. 54	REV. 55	REV. 56	REV. 57	REV. 58	REV. 59	REV. 60
REV. 61	REV. 62	REV. 63	REV. 64	REV. 65	REV. 66	REV. 67	REV. 68	REV. 69	REV. 70
REV. 71	REV. 72	REV. 73	REV. 74	REV. 75	REV. 76	REV. 77	REV. 78	REV. 79	REV. 80
REV. 81	REV. 82	REV. 83	REV. 84	REV. 85	REV. 86	REV. 87	REV. 88	REV. 89	REV. 90
REV. 91	REV. 92	REV. 93	REV. 94	REV. 95	REV. 96	REV. 97	REV. 98	REV. 99	REV. 100

SCHEMATIC
 FLUG-IN
 217

BO NET BULL DRAWING
 197-454-00A

100-255-001

100-255-002

100-255-003

100-255-004

100-255-005

100-255-006

100-255-007

100-255-008

100-255-009

100-255-010

100-255-011

100-255-012

100-255-013

100-255-014

100-255-015

100-255-016

100-255-017

100-255-018

100-255-019

100-255-020

100-255-021

100-255-022

100-255-023

100-255-024

100-255-025

100-255-026

100-255-027

100-255-028

100-255-029

100-255-030

100-255-031

100-255-032

100-255-033

100-255-034

100-255-035

100-255-036

100-255-037

100-255-038

100-255-039

100-255-040

100-255-041

100-255-042

100-255-043

100-255-044

100-255-045

100-255-046

100-255-047

100-255-048

100-255-049

100-255-050

100-255-051

100-255-052

100-255-053

100-255-054

100-255-055

100-255-056

100-255-057

100-255-058

100-255-059

100-255-060

100-255-061

100-255-062

100-255-063

100-255-064

100-255-065

100-255-066

100-255-067

100-255-068

100-255-069

100-255-070

100-255-071

100-255-072

100-255-073

100-255-074

100-255-075

100-255-076

100-255-077

100-255-078

100-255-079

100-255-080

100-255-081

100-255-082

100-255-083

100-255-084

100-255-085

100-255-086

100-255-087

100-255-088

100-255-089

100-255-090

100-255-091

100-255-092

100-255-093

100-255-094

100-255-095

100-255-096

100-255-097

100-255-098

100-255-099

100-255-100

REV.	DESCRIPTION	DATE	BY	APPROV.
L	ECO 4385	7/15/54	D	(Signature)

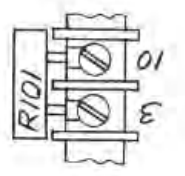
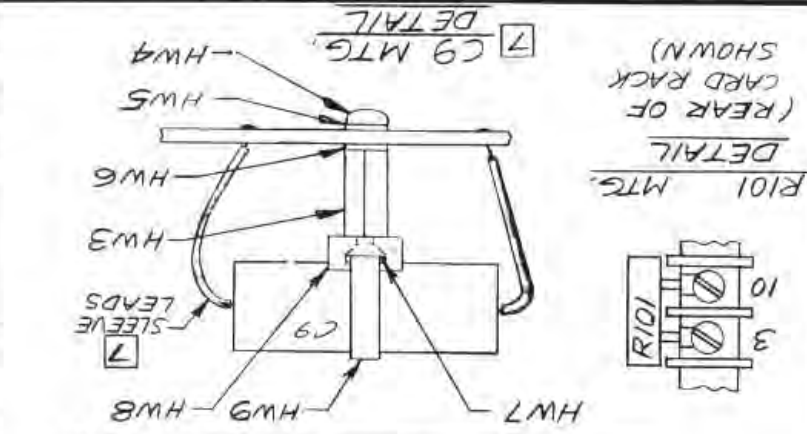
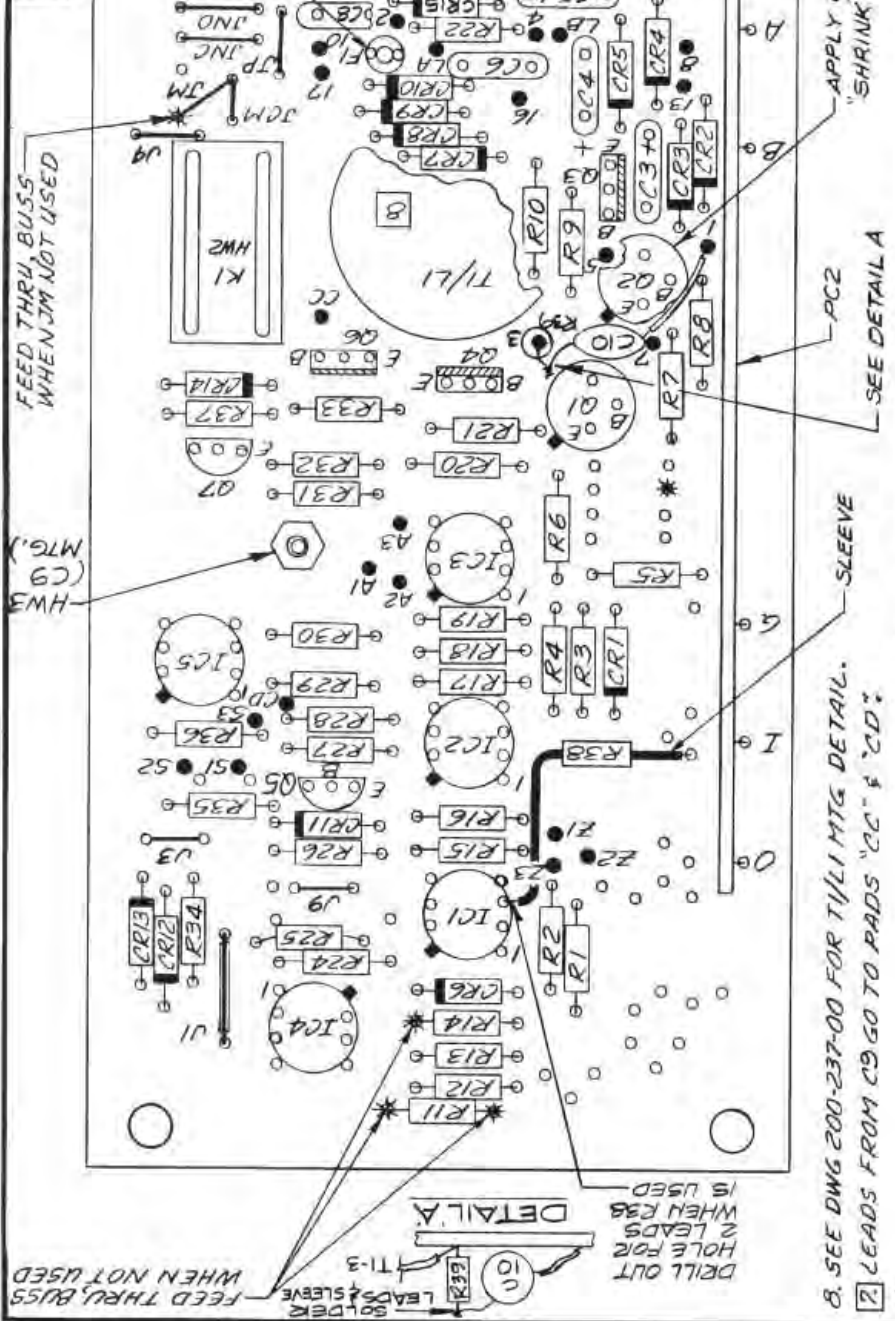

SOLDER LEADS & SLEEVE
 FEED THRU, BUSS WHEN NOT USED
 HOLE FOR 2 LEADS WHEN R38 IS USED
 DRILL OUT HOLE FOR 2 LEADS WHEN R38 IS USED
 DETAIL A

8. SEE DWG 200-237-00 FOR T1/L1 MTG. DETAIL.
- LEADS FROM C9 GO TO PADS "CC" & "CD".

ITEM NO. REG'D		PART NUMBER		MANUFACTURER		REFERENCE DESIGNATION	
MOORE INDUSTRIES INC. CALIF.		R.C. BOARD ASSEMBLY		PLUG-IN		LIT	
DRAWN: R. Kelly		CHECK: M. [Signature]		PROD. ENGR. [Signature]		SCALE: 2/1	
DO NOT SCALE DRAWING		JOB NO. 197		197-551-00L			

2. ALL LEADS & TERM. MUST BE SOLDERED TO PADS.
 1. ALL JUMPERS ARE 22AWG BUSS, TEFLON SLEEVED.
- NOTES: UNLESS OTHERWISE SPECIFIED

DO NOT SCALE DRAWING	
TOLERANCES UNLESS NOTED	DRAWN <i>Dr. Santos</i> OCT 82
X ±.1	CHECKED
XX ±.03	ENGINEER
XXX ±.010	SCALE: 2/1
ANGLES ±30'	

LIT
 PLUG-IN
 PC2

DRAWING NUMBER	197-552-00	REVISION	F
CATEGORY	ASSEMBLY		
REVISED BY	ECO 5627	DATE	8/14/82
		BY	JV
		APPROVAL	

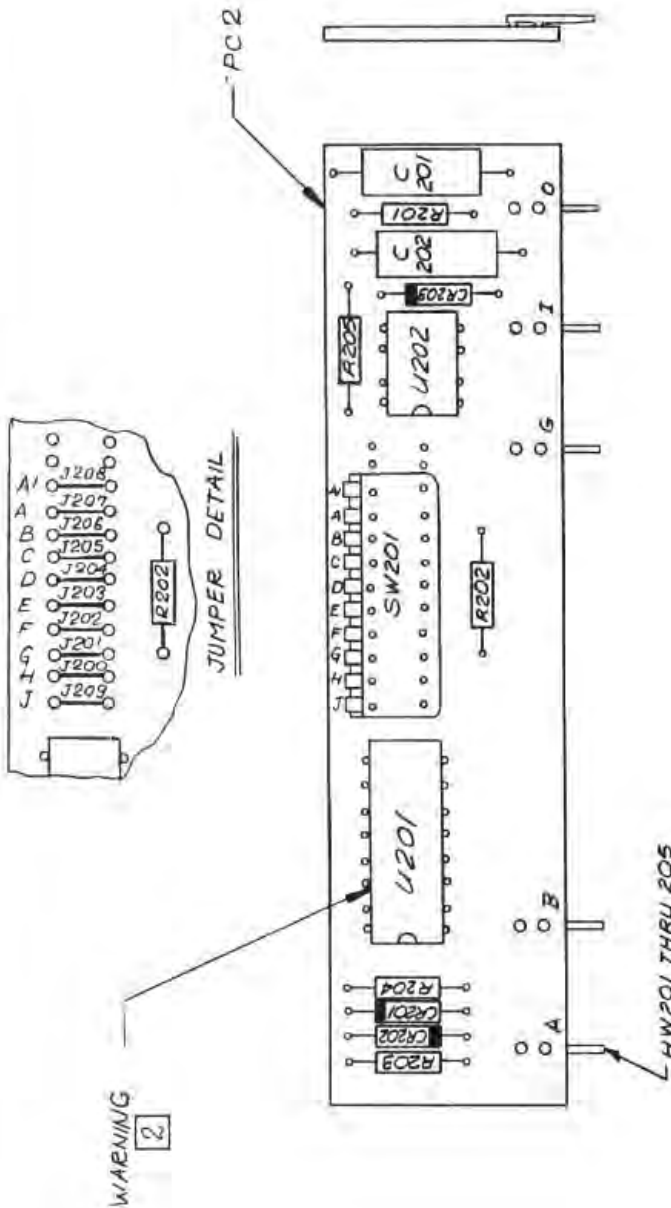

3. MOUNT HW201 THRU 205 FLAT ON PC BOARD.
 [2] DO NOT TOUCH LEADS OF U1201 WITH FINGERS UNTIL SOLDERED TO BOARD. USE LOW VOLTAGE GROUNDED SOLDERING IRON.
 1. SOLDER ALL LEADS TO PADS ON FAR SIDE ONLY.
 NOTE:

NOTICE RE PROPRIETARY INFORMATION: This drawing and the information contained herein are the proprietary property of Moore Industries International, Inc. (MII) and should not be reproduced or disclosed to any third party without the written consent of an authorized officer of MII.

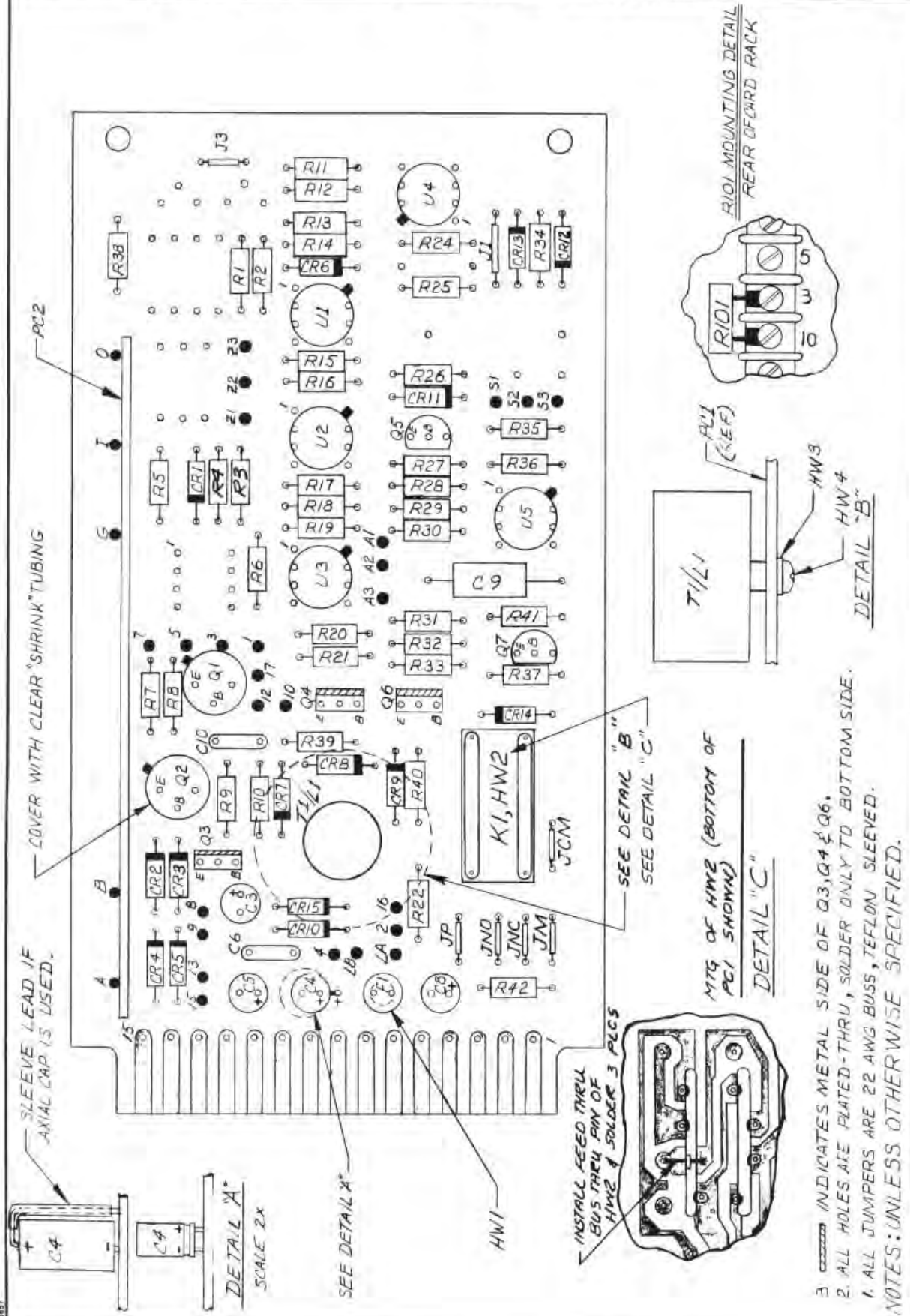

100851

CLEARPRINT 192614

- 3. INDICATES METAL SIDE OF Q3, Q4 & Q6.
 - 2. ALL HOLES ARE PLATED-THRU, SOLDER ONLY TO BOTTOM SIDE.
 - 1. ALL JUMPERS ARE 22 AWG BUSS, TEFLON SLEEVED.
- NOTES: UNLESS OTHERWISE SPECIFIED.

RETURN PROCEDURES

To return equipment to Moore Industries for repair, follow these four steps:

1. Call Moore Industries and request a Returned Material Authorization (RMA) number.

Warranty Repair –

If you are unsure if your unit is still under warranty, we can use the unit's serial number to verify the warranty status for you over the phone. Be sure to include the RMA number on all documentation.

Non-Warranty Repair –

If your unit is out of warranty, be prepared to give us a Purchase Order number when you call. In most cases, we will be able to quote you the repair costs at that time. The repair price you are quoted will be a "Not To Exceed" price, which means that the actual repair costs may be less than the quote. Be sure to include the RMA number on all documentation.

2. Provide us with the following documentation:
 - a) A note listing the symptoms that indicate the unit needs repair
 - b) Complete shipping information for return of the equipment after repair
 - c) The name and phone number of the person to contact if questions arise at the factory
3. Use sufficient packing material and carefully pack the equipment in a sturdy shipping container.
4. Ship the equipment to the Moore Industries location nearest you.

The returned equipment will be inspected and tested at the factory. A Moore Industries representative will contact the person designated on your documentation if more information is needed. The repaired equipment, or its replacement, will be returned to you in accordance with the shipping instructions furnished in your documentation.

WARRANTY DISCLAIMER

THE COMPANY MAKES NO EXPRESS, IMPLIED OR STATUTORY WARRANTIES (INCLUDING ANY WARRANTY OF MERCHANTABILITY OR OF FITNESS FOR A PARTICULAR PURPOSE) WITH RESPECT TO ANY GOODS OR SERVICES SOLD BY THE COMPANY. THE COMPANY DISCLAIMS ALL WARRANTIES ARISING FROM ANY COURSE OF DEALING OR TRADE USAGE, AND ANY BUYER OF GOODS OR SERVICES FROM THE COMPANY ACKNOWLEDGES THAT THERE ARE NO WARRANTIES IMPLIED BY CUSTOM OR USAGE IN THE TRADE OF THE BUYER AND OF THE COMPANY, AND THAT ANY PRIOR DEALINGS OF THE BUYER WITH THE COMPANY DO NOT IMPLY THAT THE COMPANY WARRANTS THE GOODS OR SERVICES IN ANY WAY.

ANY BUYER OF GOODS OR SERVICES FROM THE COMPANY AGREES WITH THE COMPANY THAT THE SOLE AND EXCLUSIVE REMEDIES FOR BREACH OF ANY WARRANTY CONCERNING THE GOODS OR SERVICES SHALL BE FOR THE COMPANY, AT ITS OPTION, TO REPAIR OR REPLACE THE GOODS OR SERVICES OR REFUND THE PURCHASE PRICE. THE COMPANY SHALL IN NO EVENT BE LIABLE FOR ANY CONSEQUENTIAL OR INCIDENTAL DAMAGES EVEN IF THE COMPANY FAILS IN ANY ATTEMPT TO REMEDY DEFECTS IN THE GOODS OR SERVICES, BUT IN SUCH CASE THE BUYER SHALL BE ENTITLED TO NO MORE THAN A REFUND OF ALL MONIES PAID TO THE COMPANY BY THE BUYER FOR PURCHASE OF THE GOODS OR SERVICES.

ANY CAUSE OF ACTION FOR BREACH OF ANY WARRANTY BY THE COMPANY SHALL BE BARRED UNLESS THE COMPANY RECEIVES FROM THE BUYER A WRITTEN NOTICE OF THE ALLEGED DEFECT OR BREACH WITHIN TEN DAYS FROM THE EARLIEST DATE ON WHICH THE BUYER COULD REASONABLY HAVE DISCOVERED THE ALLEGED DEFECT OR BREACH, AND NO ACTION FOR THE BREACH OF ANY WARRANTY SHALL BE COMMENCED BY THE BUYER ANY LATER THAN TWELVE MONTHS FROM THE EARLIEST DATE ON WHICH THE BUYER COULD REASONABLY HAVE DISCOVERED THE ALLEGED DEFECT OR BREACH.

RETURN POLICY

For a period of thirty-six (36) months from the date of shipment, and under normal conditions of use and service, Moore Industries ("The Company") will at its option replace, repair or refund the purchase price for any of its manufactured products found, upon return to the Company (transportation charges prepaid and otherwise in accordance with the return procedures established by The Company), to be defective in material or workmanship. This policy extends to the original Buyer only and not to Buyer's customers or the users of Buyer's products, unless Buyer is an engineering contractor in which case the policy shall extend to Buyer's immediate customer only. This policy shall not apply if the product has been subject to alteration, misuse, accident, neglect or improper application, installation, or operation. THE COMPANY SHALL IN NO EVENT BE LIABLE FOR ANY INCIDENTAL OR CONSEQUENTIAL DAMAGES.



WORLDWIDE • www.miinet.com

United States • info@miinet.com Tel: (818) 894-7111 • FAX: (818) 891-2816	Belgium • info@mooreind.be Tel: 03/448.10.18 • FAX: 03/440.17.97	China • sales@mooreind.sh.cn Tel: 86-21-62491499 • FAX: 86-21-62490635
Australia • sales@mooreind.com.au Tel: (02) 8536-7200 • FAX: (02) 9525-7296	The Netherlands • sales@mooreind.nl Tel: (0)344-617971 • FAX: (0)344-615920	United Kingdom • sales@mooreind.com Tel: 01293 514488 • FAX: 01293 536852